

TWIGA 600

- Cable Controls
- Three Point Linkage Mounting
- Left Hand or Right Hand Build Option
- Cushion Top Link
- LED Rear Lighting Kit
- Parallel Arm Geometry
- Totally Independent 66HP Hydraulic System
- Cast Iron Pumps and Motor
- Heavy Duty Cast Iron Gearbox
- Hydraulic Slew and Safety Breakaway
- 220 Litre Oil Capacity
- 1.2 Metre MP2 Flailhead

Optional Extras

- Precision Proportional Controls
- Remote Hydraulic Roller Adjustment
- Autopilot Control
- Oil Cooler
- Belt Drive Flailhead
- Axle Mounting System
- Quick Release Couplings
- Mechanical Quick Attach Bracket

MODEL	TWIGA 600
Maximum reach	6.0m
Machine weight	1380kg
Oil Tank capacity	220ltr
Transport width	2.6m
Gear totally independent hydraulics	STD
3-point linkage-mounting	STD
Axle mounting	Option
Right hand or left hand build	Option
LED lighting kit	STD
Tractor power required	95hp
Tractor weight required	3750kg

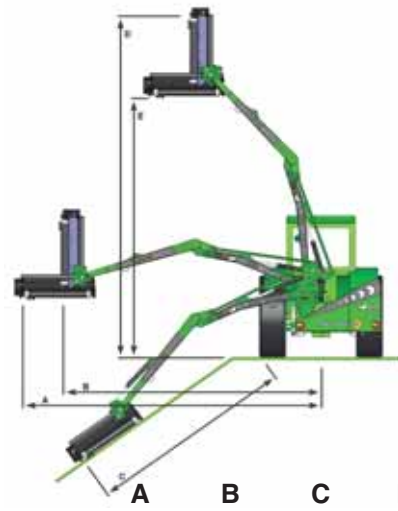

	A	B	C	D	E
TWIGA 600	6.0m	5.3m	4.2m	6.7m	5.2m

